

Product Bulletin

51.1:GX 3-Way
D103305X012
February 2009

GX 3-Way Valve and Actuator

Fisher® GX 3-Way Control Valve and Actuator System

The Fisher® GX 3-Way is a compact, state-of-the-art control valve and actuator system, designed to accurately control water, oils, steam, and other industrial fluids. The robust GX 3-way valve package is perfectly suited to address the space limitations of the OEM industry.

The GX 3-Way is rugged, reliable, and easy to select. The internal valve trim is designed to ensure long service life and avoiding unnecessary maintenance. The same construction may be used for both converging and diverging applications.

The GX 3-Way meets the requirements of both EN and ASME standards. It is available with a complete accessory package, including the FIELDVUE® DVC2000 integrated digital valve controller.

The GX 3-Way trim characteristics are designed for accurate temperature control in heat exchanger applications.

- **Side-Port Common (SPC)**—The side flange is the common pipe connection for general converging (flow-mixing) and diverging (flow-splitting) service (see figure 4). Utilizes an unbalanced plug design.

- **Bottom-Port Common (BPC)**—A balanced design used for high ΔP applications. The bottom flange is the common pipe connection for both converging and diverging service (see figure 8).



W9557

Figure 1. Fisher® GX 3-Way Control Valve, Actuator, and DVC2000 Digital Valve Controller



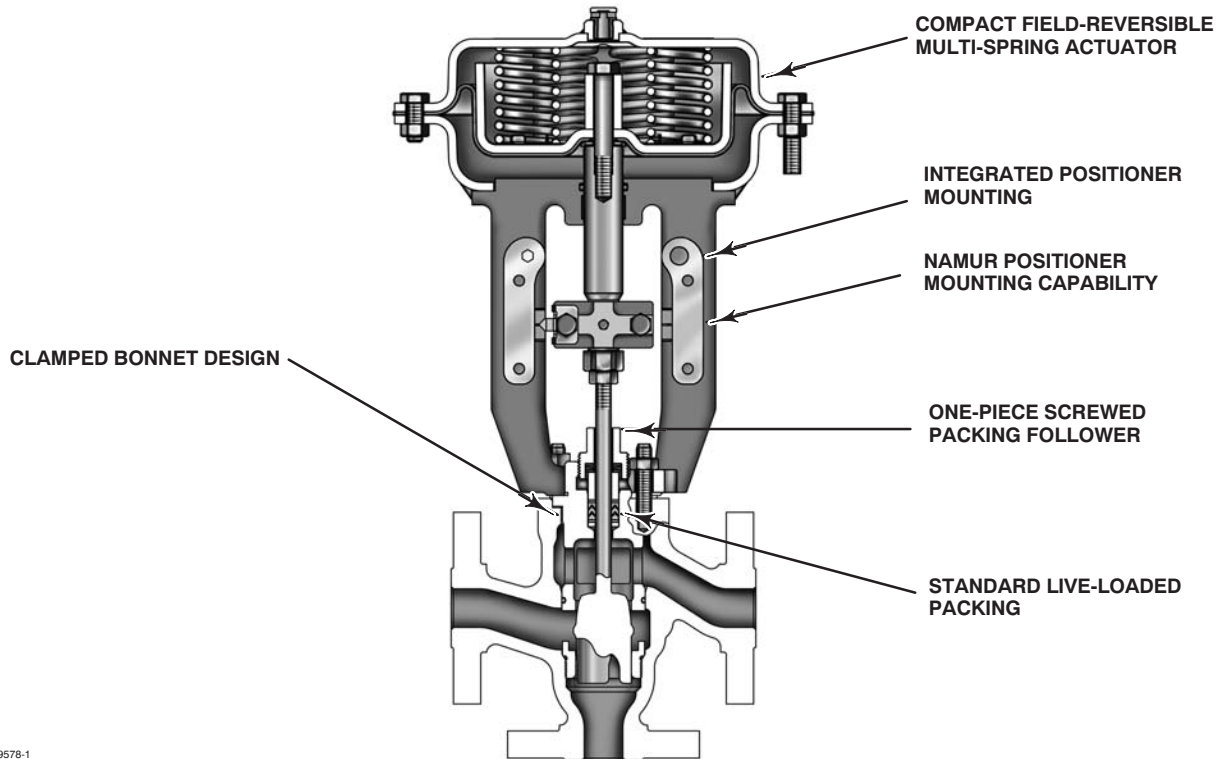

W9578-1

Figure 2. Fisher® GX 3-Way Control Valve Assembly with Port-Guided Contoured Plug (Side Port Common)

Contents

Features	2
Principle of Operation	9
GX 3-Way Control Valve Specifications and Materials of Construction	10
The GX 3-Way Diaphragm Actuator	13
Valve-Actuator Dimensions and Weights	15
GX 3-Way Actuator Accessories	16
The FIELDVUE DVC2000 Digital Valve Controller	16
Optional Positioners and Instruments	17

Features

- Easy to size and select
- No actuator sizing required--selection is automatic
- Engineered for easy maintenance
- Maximum part commonality across sizes
- Replaceable trim
- Low lifetime costs
- Robust, low-profile design
- Available with integrated, easy-to-calibrate DVC2000 digital valve controller
- Valve body sizes DN 25 to DN 100 (NPS 1 through 4)
- Pressure Classes PN 10-40, CL150 and 300
- High capacity design
- Valve body flow passage optimized for flow stability
- Shutoff capabilities: Class IV metal to metal

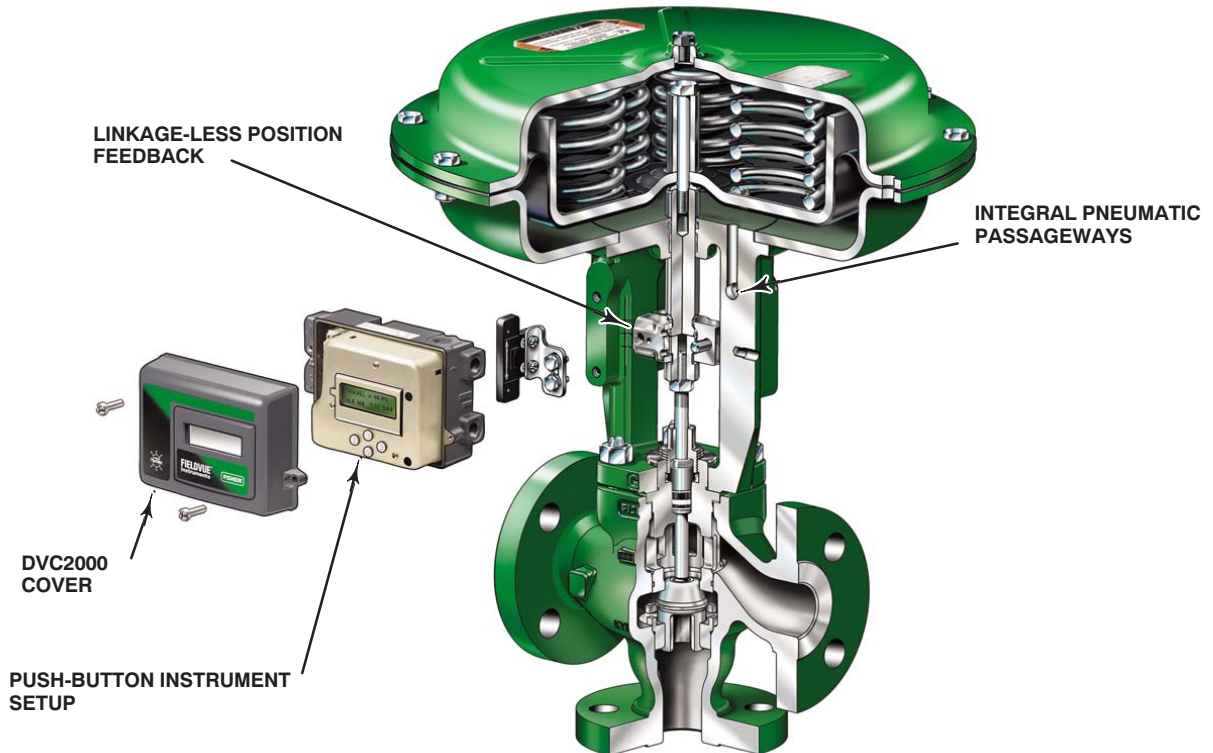

Figure 3. Fisher® GX 3-Way and DVC2000 Digital Valve Controller

Optimized valve and actuator system. Product simplicity and ease of selection form the foundation of the GX 3-Way. Mounted with a digital or analog positioner, the GX 3-Way provides high performance control across a wide range of process applications.

Compact actuator design. The multi-spring GX 3-Way actuator is a compact robust design. The GX 3-Way design has been optimized to eliminate complicated 3-way actuator sizing procedures - once the valve body and port size are selected, the actuator size is fixed.

Reliable Actuator Performance. Special actuator diaphragm material helps reduce common problems such as air oxidation, thermal aging, low temperature embrittlement, and loss of retention.

The double-sided diaphragm within the actuator helps eliminate mechanical wear-induced failure.

Modular design. The design architecture has been optimized to maximize the use of common parts across sizes. The actuator stem and stem connector are used across all GX 3-Way sizes.

Low lifetime costs. Reduced product complexity, low parts count, and part commonality all contribute to reduced inventory and maintenance costs.

Stable flow control. The flow cavity of the GX 3-Way valve body has been engineered to provide stable flow and reduce process variability. This linear stability for both converging and diverging flow is perfectly suited for temperature and pH control applications.

GX 3-Way Valve and Actuator

Live-loaded packing. The GX 3-Way comes with live-loaded PTFE V-ring packing as standard. The live-loaded design helps to seal your process to conserve valuable process fluid, while reducing emissions to the environment. The long-life and high reliability of the live-loaded system also reduces maintenance costs and process downtime. ULF (ultra low friction) graphite packing is also available for all sizes.

Easy maintenance. The simple screwed seat-ring and one-piece plug and stem design provide easy maintenance. Design simplicity and parts commonality contribute to reduced spares inventory. The integrated DVC2000 digital valve controller allows easy instrument removal, without a requirement for tubing disconnection or replacement (fail-down construction).

Digital valve controller. The GX 3-Way is available with the DVC2000 digital valve controller. The DVC2000 is easy to use, compact, and designed for easy mounting. It converts a 4-20 mA input signal into a pneumatic output signal, which feeds the control valve actuator. Instrument setup is performed with a push button and liquid crystal display (LCD) interface. This interface is protected from the environment within a sealed enclosure. The interface supports multiple languages, including German, French, Italian, Spanish, Chinese, Japanese, and English.

Intrinsic safety and non-incendive construction is available to CSA, FM, ATEX, and IEC standards. An optional module provides integrated limit switches and a position transmitter.

Integrated mounting. The DVC2000 digital valve controller integrally mounts to the GX 3-Way actuator, eliminating the need for mounting brackets. The DVC2000 transmits a pneumatic signal to the actuator casing via an air passage in the yoke leg, causing the valve to stroke (see figure 12). This eliminates the need for positioner-to-actuator tubing in the fail-down configuration.

The DVC2000 mounting interface is identical on both sides of the actuator yoke for valve body sizes DN 25 through DN 100 (NPS 1 through 4). This symmetrical design allows the DVC2000 to be easily moved from one side of the valve to the other without the need to rotate the actuator.

Linkage-less feedback. The DVC2000 digital valve controller offers as standard a non-contacting valve position feedback system. This is a true linkage-less design, which uses no levers and no touching parts between the valve stem and the positioner.

Additional Accessory selection. The GX 3-Way is available with a variety of digital or analog positioners besides the DVC2000, as well as solenoid and limit switches. The actuator is also compatible with the IEC 60534-6-1 (NAMUR) positioner mounting standard.

Product Bulletin

51.1:GX 3-Way
February 2009

GX 3-Way Valve and Actuator

Flow Directions -- Side Port Common Constructions

See figures 4, 5, 6, 7, and tables 1 and 2.

DIVERGING

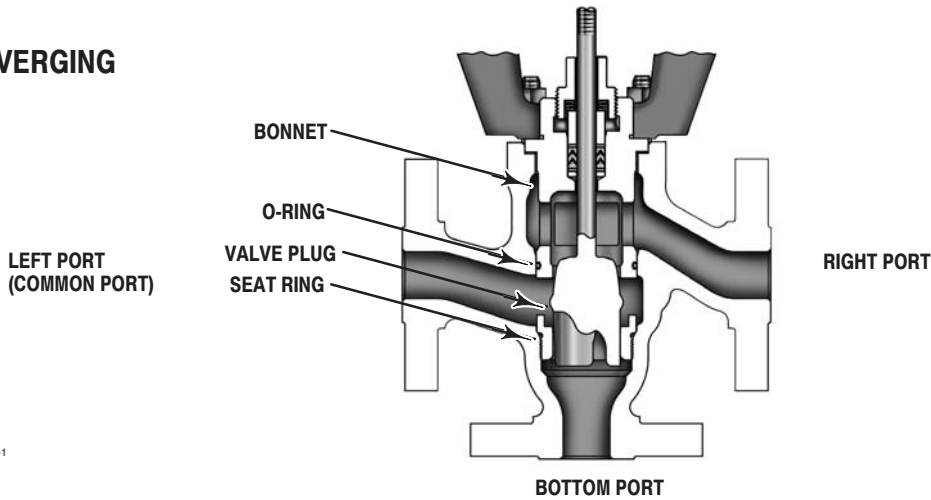

W9580-1

Figure 4. Side Port Common Construction Details for Diverging Constructions

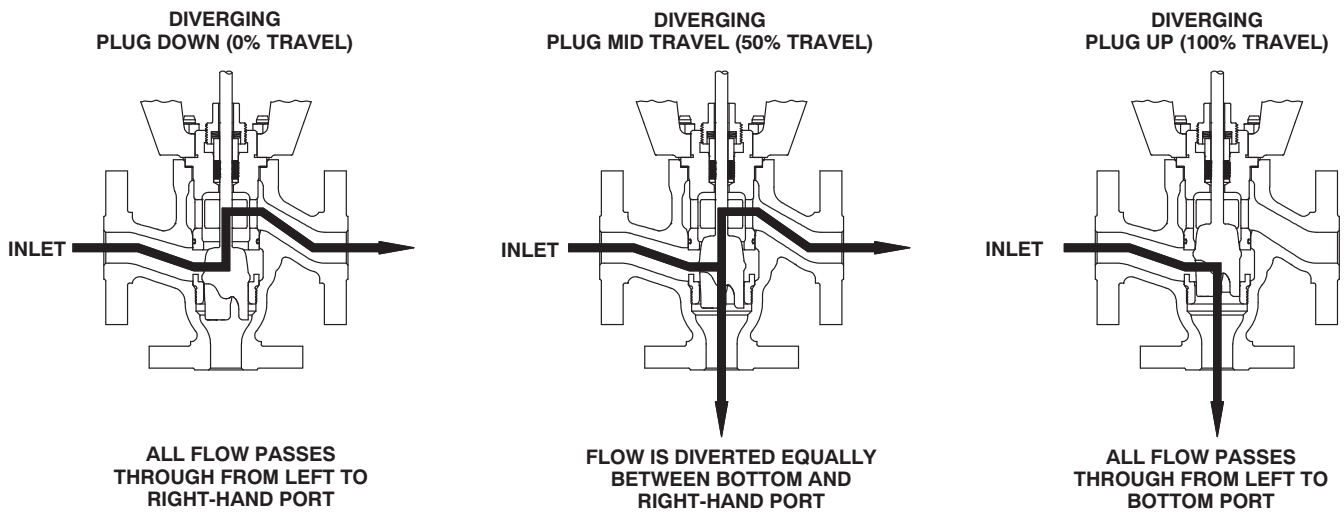

Figure 5. Fisher® GX 3-Way Flow Directions for Side Port Common Diverging Constructions

Table 1. Fisher® GX 3-Way Flow Coefficients (Cv) - Side Port Common (SPC) Diverging

VALVE SIZE	EXIT PORT (SEE FIGURE 4)	VALVE OPENING - PERCENTAGE OF TRAVEL (SEE FIGURE 5)		
		0%	50%	100%
DN 25 / NPS 1	Right Port	18	6	0
	Bottom Port	0	6	17
DN 40 / NPS 1-1/2	Right Port	29	14	0
	Bottom Port	0	14	31
DN 50 / NPS 2	Right Port	41	25	0
	Bottom Port	0	18	44
DN 80 / NPS 3	Right Port	131	80	0
	Bottom Port	0	61	116
DN 100 / NPS 4	Right Port	151	72	0
	Bottom Port	0	97	216

GX 3-Way Valve and Actuator

CONVERGING

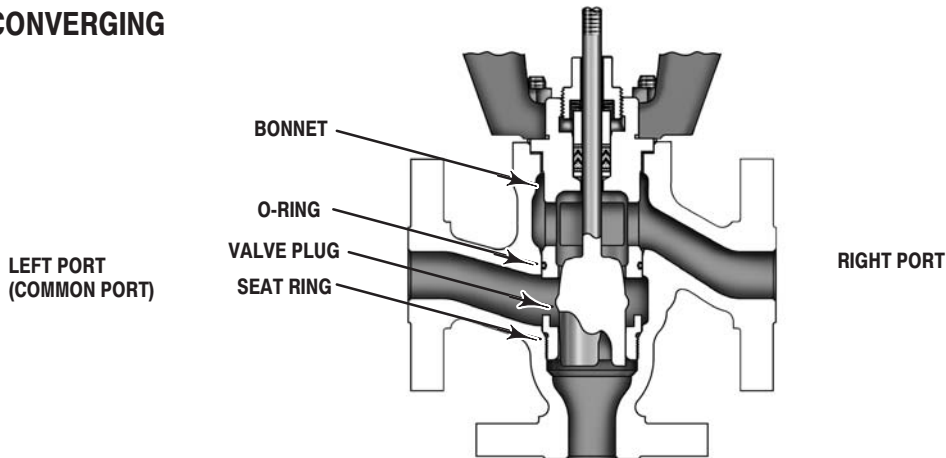

W9580-1

Figure 6. Side Port Common Construction Details for Converging Constructions

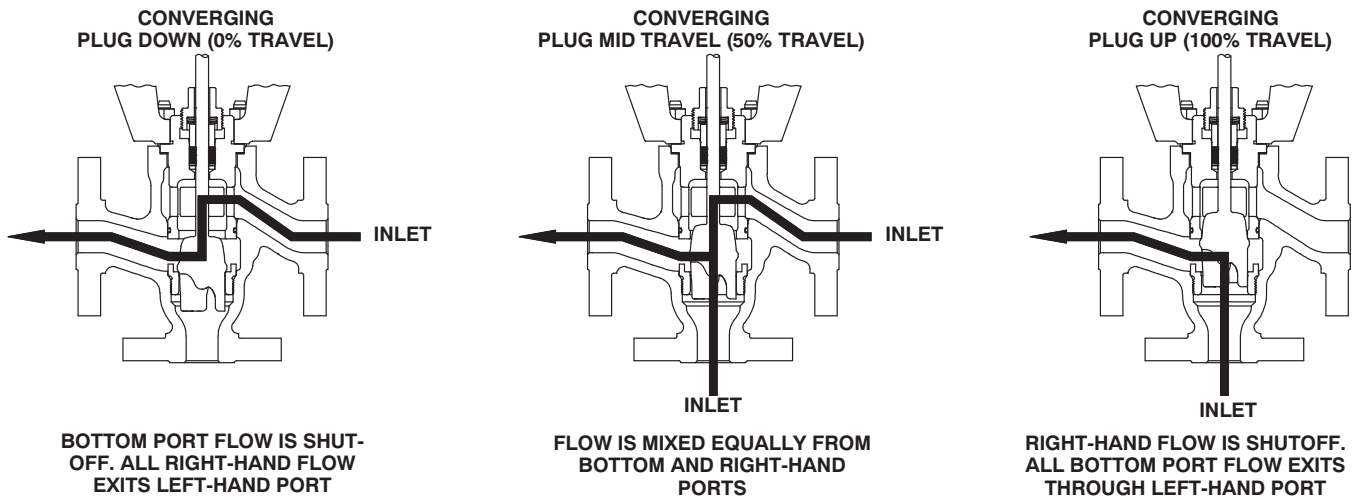

Figure 7. Fisher® GX 3-Way Flow Directions for Side Port Common Converging Constructions

Table 2. Fisher® GX 3-Way Flow Coefficients (Cv) - Side Port Common (SPC) Converging

VALVE SIZE	INLET PORT (SEE FIGURE 6)	VALVE OPENING - PERCENTAGE OF TRAVEL (SEE FIGURE 7)		
		0%	50%	100%
DN 25 / NPS 1	Right Port	15	7	0
	Bottom Port	0	8	17
DN 40 / NPS 1-1/2	Right Port	30	14	0
	Bottom Port	0	17	32
DN 50 / NPS 2	Right Port	42	26	0
	Bottom Port	0	19	44
DN 80 / NPS 3	Right Port	116	49	0
	Bottom Port	0	66	122
DN 100 / NPS 4	Right Port	160	87	0
	Bottom Port	0	93	207

Product Bulletin

51.1:GX 3-Way
February 2009

GX 3-Way Valve and Actuator

Flow Directions -- Bottom Port Common Constructions

See figures 8, 9, 10, 11, and tables 3 and 4.

DIVERGING

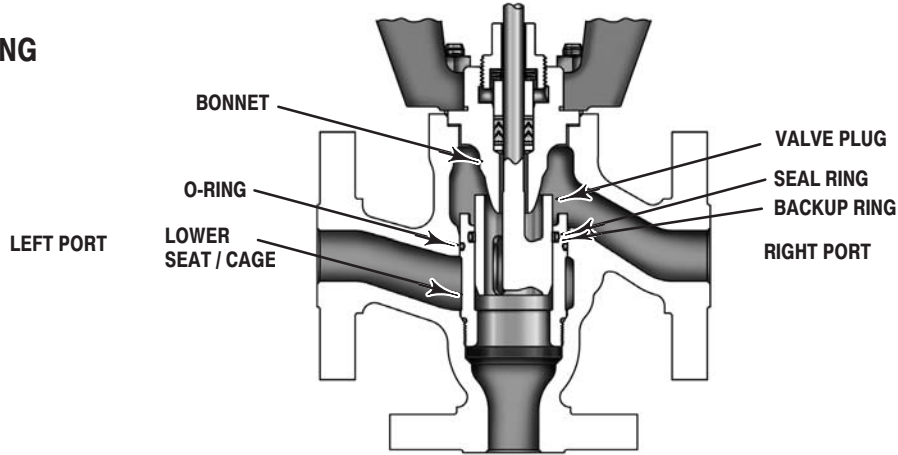

W9579-1

Figure 8. Bottom Port Common Construction Details for Diverging Constructions

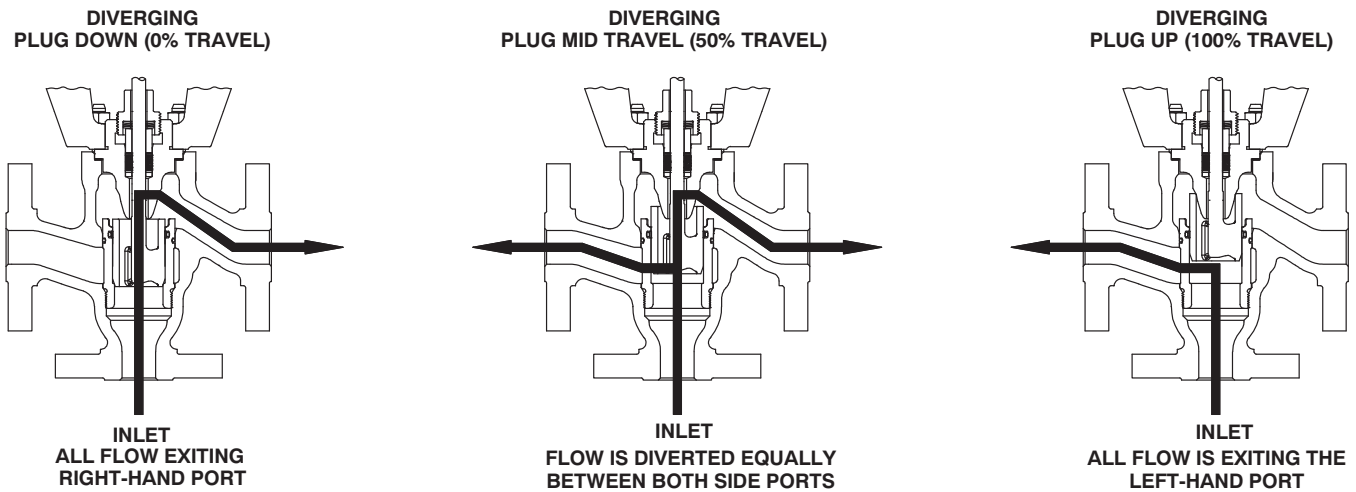
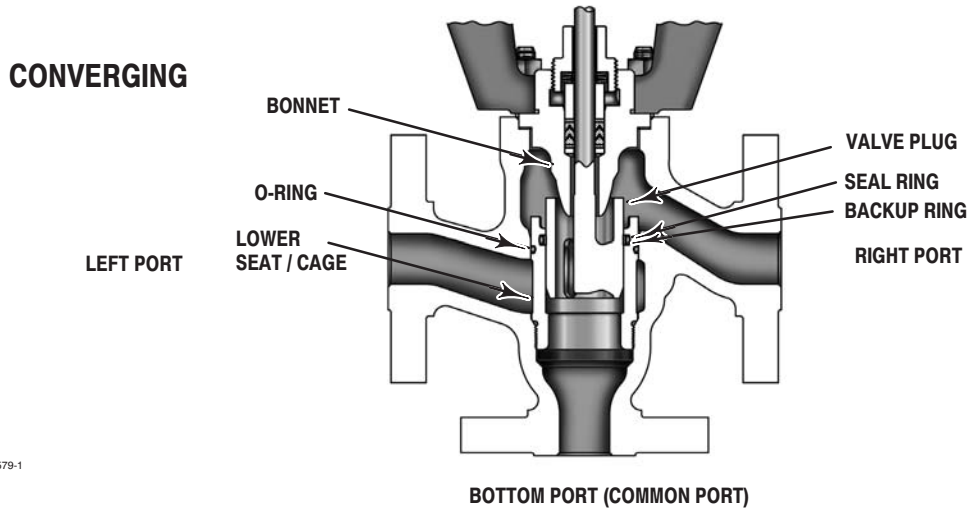

Figure 9. Fisher® GX 3-Way Flow Directions for Bottom Port Common Diverging Constructions

Table 3. Fisher® GX 3-Way Flow Coefficients (Cv) - Bottom Port Common (BPC) Diverging

VALVE SIZE	EXIT PORT (SEE FIGURE 8)	VALVE OPENING - PERCENTAGE OF TRAVEL (SEE FIGURE 9)		
		0%	50%	100%
DN 25 / NPS 1	Left Port	0	8	16
	Right Port	14	6	0
DN 40 / NPS 1-1/2	Left Port	0	22	44
	Right Port	40	23	0
DN 50 / NPS 2	Left Port	0	31	60
	Right Port	61	35	0
DN 80 / NPS 3	Left Port	0	85	171
	Right Port	140	75	0
DN 100 / NPS 4	Left Port	0	96	185
	Right Port	176	88	0

GX 3-Way Valve and Actuator



W9579-1

Figure 10. Bottom Port Common Construction Details for Converging Constructions

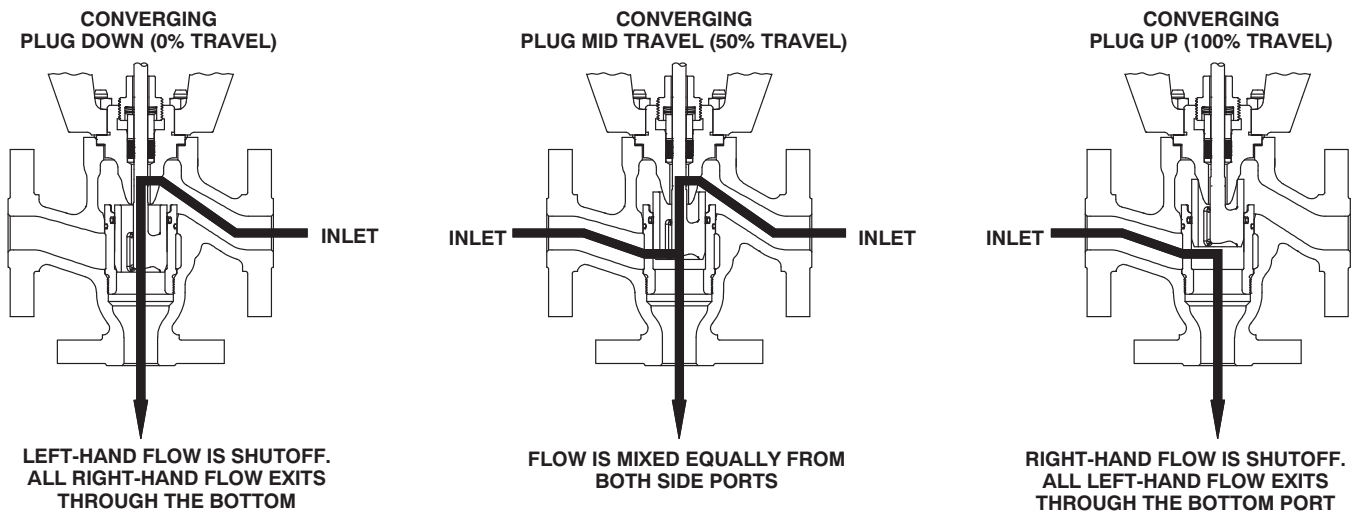
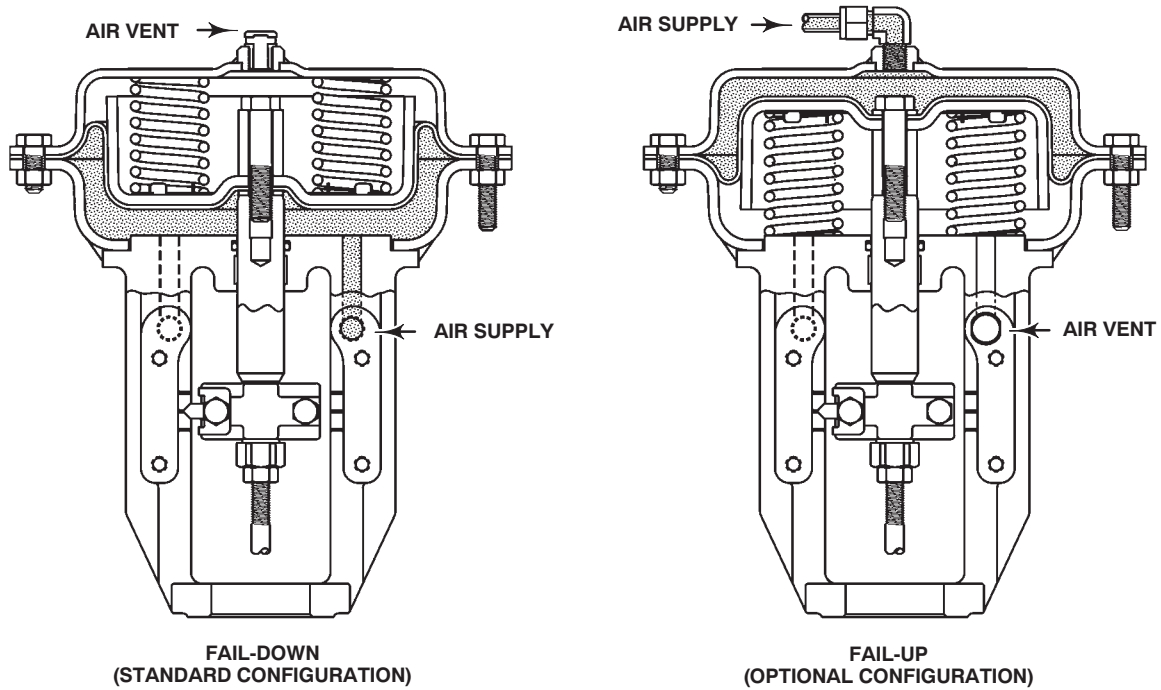

Figure 11. Fisher® GX 3-Way Flow Directions for Bottom Port Common Converging Constructions

Table 4. Fisher® GX 3-Way Flow Coefficients (Cv) - Bottom Port Common (BPC) Converging

VALVE SIZE	INLET PORT (SEE FIGURE 10)	VALVE OPENING - PERCENTAGE OF TRAVEL (SEE FIGURE 11)		
		0%	50%	100%
DN 25 / NPS 1	Left Port	0	8	18
	Right Port	14	6	0
DN 40 / NPS 1-1/2	Left Port	0	19	46
	Right Port	45	20	0
DN 50 / NPS 2	Left Port	0	26	65
	Right Port	61	27	0
DN 80 / NPS 3	Left Port	0	89	172
	Right Port	142	53	0
DN 100 / NPS 4	Left Port	0	96	191
	Right Port	165	60	0

Principle of Operation - GX 3-Way Actuator



E0896-2/IL

Figure 12. Fisher® GX 3-Way Principle of Operation -- Actuator Fail Position

Integrated Air Supply. When mounted with the DVC2000 digital valve controller, the GX 3-Way uses an integrated actuator air supply system. In the fail-down configuration, air is supplied to the lower

actuator casing via a port on the actuator yoke face -- no tubing is required. In the fail-up configuration, air is supplied to the upper casing via tubing.

GX 3-Way Valve and Actuator

GX 3-Way Control Valve Specifications and Materials of Construction

See tables 5 and 6.

Table 5. Fisher® GX 3-Way Valve Specifications

Specifications	EN	ASME	
Valve Body Size	DN 25, 40, 50, 80, 100	NPS 1, 1.5, 2, 3, 4	
Pressure Rating	PN 10 / 16 / 25 / 40 per EN 1092-1	CL150 / 300 per ASME B16.34	
End Connections	Flanged raised face per EN 1092-1	Flanged raised face per ASME B16.5	
Valve Body Materials	1.0619 steel	ASME SA216 WCC steel	
	1.4409 stainless steel	ASME SA351 CF3M stainless steel	
Bonnet Materials	1.4409 stainless steel / CoCr-A	SA351 CF3M SST / CoCr-A	
Face-to-Face Dimensions	See table 13		
Shutoff per IEC 60534-4 and ANSI/FCI 70-2	Metal seat - Class IV (standard)		
Flow Direction	Converging and Diverging		
Trim Style	Type	Plug Sizes	Description
	Side Port Common	All sizes	Unbalanced Port-guided
	Bottom Port Common	All sizes	Balanced Cage-guided

Table 6. Materials (Other Valve Components)

Component	Material	
Packing Follower	S21800 SST screwed follower	
Body/Bonnet Bolting and Nuts	SA193-B7 studs / SA194-2H nuts with NCF2 coating for carbon steel and stainless steel constructions	
Packing	Live-loaded PTFE V-ring (standard) with N07718 Belleville springs	
	Live-loaded Graphite ULF (optional) with N07718 Belleville springs	
Bonnet Gasket	Graphite laminate	
Bottom Port Common Trim (all sizes)	Carbon-Filled PTFE Seal Ring	
	Back-up Rings	NBR (Standard) -46 to 82°C (-50 to 180°F)
		Ethylene Propylene [EPDM] (Optional): -46 to 232°C (-50 to 450°F) in steam and hot water; -46 to 121°C (-50 to 250°F) in air (EPDM is not recommended for use in hydrocarbons)
		FKM Fluorocarbon (Optional): -18 to 204°C (0 to 400°F) (Applicable in a wide variety of solvents, chemicals, and hydrocarbons. Avoid use with steam, ammonia, or hot water over 82°C [180°F])
O-ring	NBR (Standard) -46 to 82°C (-50 to 180°F)	
	Ethylene Propylene [EPDM] (Optional): -46 to 232°C (-50 to 450°F) in steam and hot water; -46 to 121°C (-50 to 250°F) in air (EPDM is not recommended for use in hydrocarbons)	
	FKM Fluorocarbon (Optional): -18 to 204°C (0 to 400°F) (Applicable in a wide variety of solvents, chemicals, and hydrocarbons. Avoid use with steam, ammonia, or hot water over 82°C [180°F])	

Product Bulletin

51.1:GX 3-Way
February 2009

GX 3-Way Valve and Actuator

Table 7. Trim Materials (all sizes)

Valve Body Construction	Trim Type	Stem	Plug	Upper Seat	Lower Seat/Cage
Carbon steel (1.0619 / WCC)	Bottom Port Common	S31603 strain hardened	CF3M Chrome-plated	CF3M/CoCr-A	CF3M
	Side Port Common	S31603 strain hardened	CF3M	CF3M/CoCr-A	CF3M
Stainless steel (1.4409 / CF3M)	Bottom Port Common	S31603 strain hardened	CF3M Chrome-plated	CF3M/CoCr-A	CF3M
	Side Port Common	S31603 strain hardened	CF3M	CF3M/CoCr-A	CF3M

Table 8. Allowable Temperature Ranges for Valve Body, Bonnet and Trim^(1, 2)

VALVE BODY / BONNET MATERIAL	BONNET STYLE	PACKING	GASKET	TRIM STYLE	TEMPERATURE			
					°C		°F	
					Min	Max	Min	Max
1.0619/SA216 WCC Steel	Standard	PTFE or Graphite ULF	Graphite laminate	Bottom Port Common, Side Port Common	-29	232	-20	450
1.4409/SA351 CF3M SST	Standard	PTFE or Graphite ULF	Graphite laminate	Bottom Port Common, Side Port Common	-46	232	-50	450

1. Bonnet O-ring and back-up ring materials used on BPC trim may be limited by temperature and application.
2. Minimum allowable temperature for PN series flanges is -10°C (14°F).

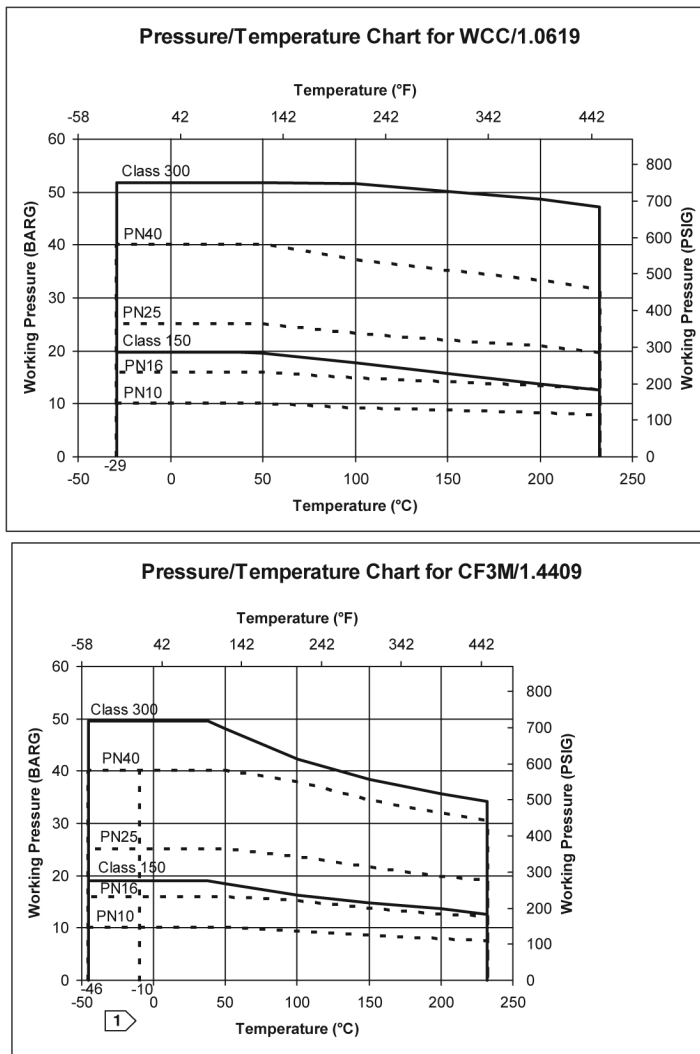

Figure 13. Material Pressure/Temperature Curves

GX 3-Way Valve and Actuator

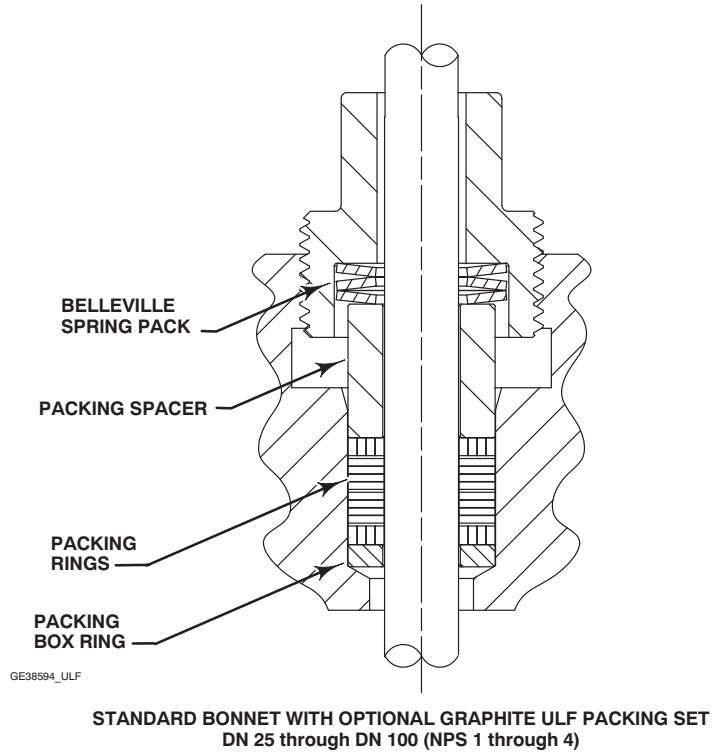
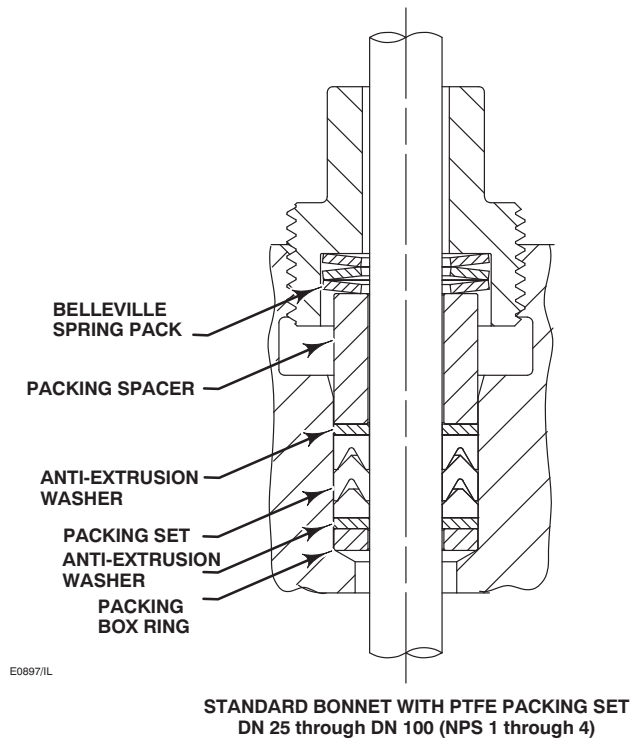

Figure 14. Fisher® GX 3-Way Packing

The GX 3-Way Diaphragm Actuator

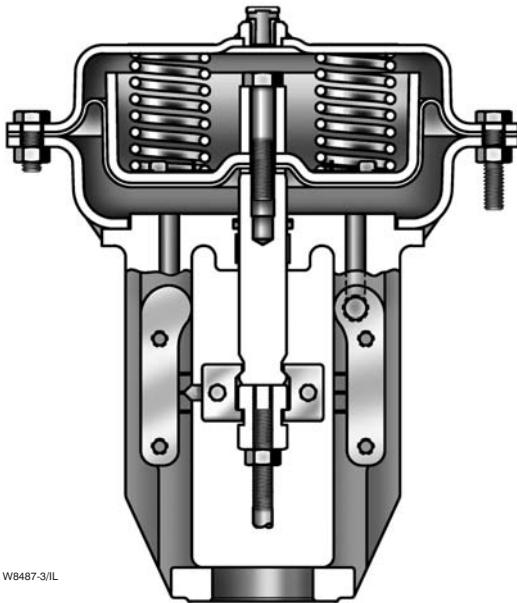

Figure 15. Fisher® GX 3-Way Actuator

The GX 3-Way uses a multi-spring, pneumatic diaphragm actuator (see figure 15). It is capable of air supply pressures up to 5.0 barg (72 psig), allowing valve shutoff at high pressure drops (see table 11).

The GX 3-Way product selection system automatically matches the actuator to the valve, eliminating the need for complex actuator sizing procedures.

The multiple spring design provides the preload, eliminating the need for bench set adjustment. The actuator is available in fail-down and fail-up configurations.

The GX 3-Way actuator can be used for throttling or on-off service.

The GX 3-Way is available with the integrated DVC2000 digital valve controller. Other digital and analog positioners are available, as well as optional solenoids and limit switches.

Table 9. Actuator Specifications

Description	Pneumatic spring-return diaphragm actuator
Operating Principle	Fail-down (standard configuration) Fail-up (optional configuration)
Operating Pressure Ranges	See tables 11 and 12
Ambient Temperature	-29 to 82°C (-20 to 180°F)
Pressure Connection (Fail-Up Construction)	G 1/4 female casing connection
Finish	Powder coat polyester

Table 10. Materials of Construction

Part	Material
Upper and Lower Casings	AISI 1010 stamped carbon steel
Springs	Steel
Diaphragm	NBR and nylon
Diaphragm Plate	AISI 1010 stamped carbon steel
Yoke	Carbon steel
Casing Fasteners	A2-70 stainless steel bolts and nuts
Actuator Rod	Stainless steel
Stem Connector	CF3M
Stem Connector Fasteners	SA193-B7 bolts with NCF2 coating
Stem Bushing	High-density polyethylene (HDPE)
Stem Seal	NBR

GX 3-Way Valve and Actuator

Actuator Selection

With the GX 3-Way, actuator selection has never been easier. Once the valve size has been determined, the actuator is automatically selected.

The following tables provide the maximum allowable

pressure drops for the GX 3-Way. See table 11 for Side Port Common construction and table 12 for Bottom Port Common construction. For optimal performance, the GX 3-Way should be operated with a FIELDVUE digital valve controller.

Table 11. Maximum Allowable Pressure Drop (Side Port Common)

VALVE SIZE	ACTUATOR SIZE	FLOW DIRECTION	PACKING	FAIL-DOWN					FAIL-UP				
				Operating Pressure				MAX DP @ Maximum Supply Pressure	Operating Pressure				MAX DP @ Maximum Supply Pressure
				3 bar	3.44 bar	4 bar	5 bar		3 bar	3.44 bar	4 bar	5 bar	
DN25	225	Converging	PTFE	18.1	21.7	21.7	21.7	21.7 bar @ 5.0 bar	19.7	20.2	20.2	20.2	20.2 bar @ 5.0 bar
			ULF	12.2	16.2	16.2	16.2	16.2 bar @ 5.0 bar	14.2	14.3	14.3	14.3	14.3 bar @ 5.0 bar
		Diverging	PTFE	14.0	14.0	14.0	14.0	14.0 bar @ 5.0 bar	14.0	14.0	14.0	14.0	14.0 bar @ 5.0 bar
			ULF	14.0	14.0	14.0	14.0	14.0 bar @ 5.0 bar	14.0	14.0	14.0	14.0	14.0 bar @ 5.0 bar
DN40	225	Converging	PTFE	18.1	21.7	21.7	21.7	21.7 bar @ 5.0 bar	19.7	20.2	20.2	20.2	20.2 bar @ 5.0 bar
			ULF	12.2	16.2	16.2	16.2	16.2 bar @ 5.0 bar	14.2	14.3	14.3	14.3	14.3 bar @ 5.0 bar
		Diverging	PTFE	14.0	14.0	14.0	14.0	14.0 bar @ 5.0 bar	14.0	14.0	14.0	14.0	14.0 bar @ 5.0 bar
			ULF	14.0	14.0	14.0	14.0	14.0 bar @ 5.0 bar	14.0	14.0	14.0	14.0	14.0 bar @ 5.0 bar
DN50	750	Converging	PTFE	29.7	48.4	48.4	---	48.4 bar @ 4.0 bar	34.6	44.9	44.9	---	44.9 bar @ 4.0 bar
			ULF	26.5	45.5	45.5	---	45.5 bar @ 4.0 bar	31.8	41.7	41.7	---	41.7 bar @ 4.0 bar
		Diverging	PTFE	30.0	30.0	30.0	---	30.0 bar @ 4.0 bar	30.0	30.0	30.0	---	30.0 bar @ 4.0 bar
			ULF	30.0	30.0	30.0	---	30.0 bar @ 4.0 bar	30.0	30.0	30.0	---	30.0 bar @ 4.0 bar
DN80	750	Converging	PTFE	8.1	16.7	24.2	---	24.2 bar @ 4.0 bar	8.9	17.1	24.0	---	24.0 bar @ 4.0 bar
			ULF	6.8	15.4	22.9	---	22.9 bar @ 4.0 bar	7.7	15.9	22.7	---	22.7 bar @ 4.0 bar
		Diverging	PTFE	16.0	16.0	16.0	---	16.0 bar @ 4.0 bar	16.0	16.0	16.0	---	16.0 bar @ 4.0 bar
			ULF	16.0	16.0	16.0	---	16.0 bar @ 4.0 bar	16.0	16.0	16.0	---	16.0 bar @ 4.0 bar
DN100	750	Converging	PTFE	4.8	9.9	14.6	---	14.6 bar @ 4.0 bar	5.4	10.4	14.3	---	14.3 bar @ 4.0 bar
			ULF	4.0	9.2	13.9	---	13.9 bar @ 4.0 bar	4.6	9.6	13.5	---	13.5 bar @ 4.0 bar
		Diverging	PTFE	10.0	10.0	10.0	---	10.0 bar @ 4.0 bar	10.0	10.0	10.0	---	10.0 bar @ 4.0 bar
			ULF	10.0	10.0	10.0	---	10.0 bar @ 4.0 bar	10.0	10.0	10.0	---	10.0 bar @ 4.0 bar

Table 12. Maximum Allowable Pressure Drop (Bottom Port Common)

VALVE SIZE	ACTUATOR SIZE	FLOW DIRECTION	PACKING	FAIL-DOWN					FAIL-UP				
				Operating Pressure				MAX DP @ Maximum Supply Pressure	Operating Pressure				MAX DP @ Maximum Supply Pressure
				3 bar	3.44 bar	4 bar	5 bar		3 bar	3.44 bar	4 bar	5 bar	
DN25	225	Converging	PTFE	32.4	50.1	51.7	51.7	51.7 bar @ 5.0 bar	36.2	36.2	36.2	36.2	36.2 bar @ 5.0 bar
			ULF	21.7	39.4	51.7	51.7	51.7 bar @ 5.0 bar	25.6	25.6	25.6	25.6	25.6 bar @ 5.0 bar
		Diverging	PTFE	28.0	28.0	28.0	28.0	28.0 bar @ 5.0 bar	28.0	28.0	28.0	28.0	28.0 bar @ 5.0 bar
			ULF	28.0	28.0	28.0	28.0	28.0 bar @ 5.0 bar	28.0	28.0	28.0	28.0	28.0 bar @ 5.0 bar
DN40	225	Converging	PTFE	25.0	38.7	51.7	51.7	51.7 bar @ 5.0 bar	27.9	27.9	27.9	27.9	27.9 bar @ 5.0 bar
			ULF	16.8	30.5	47.9	51.7	51.7 bar @ 5.0 bar	19.7	19.7	19.7	19.7	19.7 bar @ 5.0 bar
		Diverging	PTFE	22.0	22.0	22.0	22.0	22.0 bar @ 5.0 bar	22.0	22.0	22.0	22.0	22.0 bar @ 5.0 bar
			ULF	22.0	22.0	22.0	22.0	22.0 bar @ 5.0 bar	22.0	22.0	22.0	22.0	22.0 bar @ 5.0 bar
DN50	750	Converging	PTFE	36.1	51.7	51.7	---	51.7 bar @ 4.0 bar	51.7	51.7	51.7	---	51.7 bar @ 4.0 bar
			ULF	32.2	51.7	51.7	---	51.7 bar @ 4.0 bar	50.7	50.7	50.7	---	50.7 bar @ 4.0 bar
		Diverging	PTFE	30.0	30.0	30.0	---	30.0 bar @ 4.0 bar	30.0	30.0	30.0	---	30.0 bar @ 4.0 bar
			ULF	30.0	30.0	30.0	---	30.0 bar @ 4.0 bar	30.0	30.0	30.0	---	30.0 bar @ 4.0 bar
DN80	750	Converging	PTFE	15.0	31.0	51.3	---	51.3 bar @ 4.0 bar	44.6	44.6	44.6	---	44.6 bar @ 4.0 bar
			ULF	12.6	28.6	48.9	---	48.9 bar @ 4.0 bar	42.2	42.2	42.2	---	42.2 bar @ 4.0 bar
		Diverging	PTFE	25.0	25.0	25.0	---	25.0 bar @ 4.0 bar	25.0	25.0	25.0	---	25.0 bar @ 4.0 bar
			ULF	25.0	25.0	25.0	---	25.0 bar @ 4.0 bar	25.0	25.0	25.0	---	25.0 bar @ 4.0 bar
DN100	750	Converging	PTFE	15.0	31.0	51.3	---	51.3 bar @ 4.0 bar	44.6	44.6	44.6	---	44.6 bar @ 4.0 bar
			ULF	12.6	28.6	48.9	---	48.9 bar @ 4.0 bar	42.2	42.2	42.2	---	42.2 bar @ 4.0 bar
		Diverging	PTFE	25.0	25.0	25.0	---	25.0 bar @ 4.0 bar	25.0	25.0	25.0	---	25.0 bar @ 4.0 bar
			ULF	25.0	25.0	25.0	---	25.0 bar @ 4.0 bar	25.0	25.0	25.0	---	25.0 bar @ 4.0 bar

Product Bulletin

51.1:GX 3-Way
February 2009

GX 3-Way Valve and Actuator

Valve-Actuator Dimensions and Weights

See figure 16 and table 13.

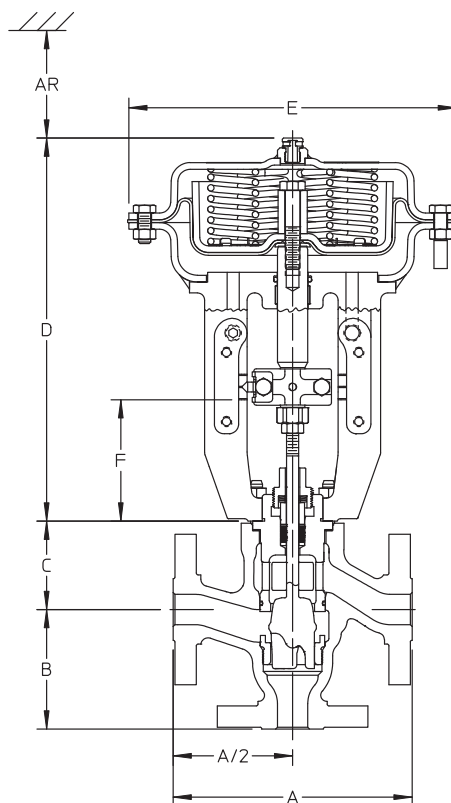

Figure 16. Fisher® GX 3-Way Dimensions (also see table 13)

Table 13. Fisher® GX 3-Way Dimensions and Weights

VALVE SIZE	TYPE	PORT DIA	ACTUATOR SIZE	TRAVEL	A			B			C	D	E Casing Dia	F (AR) Removal Height ⁽¹⁾	TOTAL WEIGHT
					PN10 - PN40	CL150	CL300	PN10 - PN40	CL150	CL300	Bonnet	Actuator Height			
					mm	mm	mm	mm	mm	mm	mm	mm			
DN 25/ NPS 1	BPC	36	225	19	197	184	197	98.5	92	98.5	73	313	270	115	26
	SPC				235	222	235	117.5	111	117.5	76	313	270	115	28
DN 40/ NPS 1-1/2	BPC	46	225	19	267	254	267	133.5	127	133.5	95	342	430	115	66
	SPC	36			318	298	318	159	149	159	119	395	430	145	97
DN 50/ NPS 2	BPC	70	750	38	368	352	368	184	176	184	119	395	430	145	123
	SPC	46													

1. Clearance required for removing actuator from installed valve body.

GX 3-Way Valve and Actuator

Table 14. Positioner Selection Guidelines

Type	Digital I/P ⁽¹⁾	I/P ⁽²⁾	P/P ⁽³⁾	Intrinsic Safety ⁽⁴⁾	Flameproof / Explosion Proof ⁽⁴⁾	Non- Incendive ⁽⁴⁾
DVC2000	X			X		X
DVC6030	X			X	X	X
3661		X		X		X
3660			X			

1. Digital I/P - microprocessor based electro-pneumatic with HART communication.
2. I/P - electro-pneumatic
3. P/P - pneumatic
4. Refer to Fisher bulletin 9.2:001 for instrument hazardous area classification details.

GX 3-Way Actuator Accessories

The GX 3-Way is available with a variety of pneumatic (P/P), electro-pneumatic (I/P), and digital valve positioners, as well as limit switches and solenoids. Table 14 provides the basic features of the positioners offered with the GX 3-Way actuator.

The FIELDVUE® DVC2000 Digital Valve Controller

The DVC2000 digital valve controller (figure 17) is simple to use, compact, and designed for the GX 3-Way control valve. It converts a 4-20mA input signal into a pneumatic output signal, which feeds the control valve actuator. Instrument setup is performed with a pushbutton and liquid crystal display (LCD) interface. This interface is protected from the environment within an IP66 enclosure. Multiple languages are supported with the local interface including German, French, Italian, Spanish, Chinese, Japanese, Portuguese, Russian, Polish, Czech, Arabic, and English. Additionally, HART® communication is supported over the 4-20mA loop wiring.

The DVC2000 is designed to be integrally mounted to the GX 3-Way actuator, avoiding the need for mounting brackets. The DVC2000 mounts directly to an interface pad on the actuator yoke leg with a secure 3-point mounting. An internal passage inside the yoke leg transmits the pneumatic signal to the actuator casing, eliminating the need for external tubing (in the fail-down configuration).



W8755

Figure 17. FIELDVUE® DVC2000 Digital Valve Controller

The high-performance linkage-less position feedback system eliminates physical contact between the valve stem and the positioner. There are no wearing parts so cycle life is maximized. Additionally, the elimination of levers and linkages reduces the number of mounting parts and the mounting complexity. Positioner replacement and maintenance is simplified because the feedback parts stay connected to the actuator.

The DVC2000 is available with an optional module which includes two (2) integral limit switches and a stem position transmitter. The limit switches are configurable for open and closed valve indication. The position transmitter provides a 4-20mA signal for valve position feedback verification. As an integral component to the instrument, this option module avoids the need for difficult-to-mount external switches and transmitters.

Designed to meet intrinsic safety and non-incendive requirements, this instrument delivers scalable functionality and high performance in a small package.

Product Bulletin

51.1:GX 3-Way
February 2009

GX 3-Way Valve and Actuator

Optional Positioners and Instruments

3660 and 3661 Valve Positioners

The 3660 pneumatic and 3661 electro-pneumatic positioners are rugged, accurate, and feature low steady-state air consumption. Designed to meet intrinsic safety requirements, these positioners offer simple functionality in a small package. (See table 14.)

DVC6030/DVC6030f Digital Valve Controller

The DVC6030/DVC6030f digital valve controller is a communicating, microprocessor-based instrument. Using HART or FOUNDATION™ fieldbus communication protocol, access to critical instrument, valve, and process conditions is provided. When used with AMS® ValveLink®

Software, valve diagnostic tests can be run while the valve is in service to advise you of the performance of the entire control valve assembly. Designed to meet a broad range of hazardous area classifications, this instrument offers maximum functionality to improve your process performance. (See figure 18 and table 14.)



W7963-1/IL

Figure 18. FIELDVUE® DVC6030 Digital Valve Controller

Note

Neither Emerson, Emerson Process Management, nor any of their affiliated entities assumes responsibility for the selection, use, or maintenance of any product. Responsibility for the selection, use, and maintenance of any product remains with the purchaser and end-user.

Product Bulletin

51.1:GX 3-Way
February 2009

GX 3-Way Valve and Actuator

GX 3-Way Valve and Actuator

Product Bulletin

51.1:GX 3-Way
February 2009

FIELDVUE, ValveLink, Whisper Trim, AMS, and Fisher are marks owned by one of the companies in the Emerson Process Management business division of Emerson Electric Co. Emerson Process Management, Emerson, and the Emerson logo are trademarks and service marks of Emerson Electric Co. HART is a mark owned by the HART Communications Foundation. FOUNDATION fieldbus is a mark owned by the Fieldbus Foundation. All other marks are the property of their respective owners. This product may be covered by one or more of the following patents: 6,866,244; 6,827,001; and 6,789,784 or under pending patents.

The contents of this publication are presented for informational purposes only, and while every effort has been made to ensure their accuracy, they are not to be construed as warranties or guarantees, express or implied, regarding the products or services described herein or their use or applicability. All sales are governed by our terms and conditions, which are available upon request. We reserve the right to modify or improve the designs or specifications of such products at any time without notice. Neither Emerson, Emerson Process Management, nor any of their affiliated entities assumes responsibility for the selection, use or maintenance of any product. Responsibility for proper selection, use, and maintenance of any product remains solely with the purchaser and end-user.

Emerson Process Management

Marshalltown, Iowa 50158 USA

Sorocaba, 18087 Brazil

Chatham, Kent ME4 4QZ UK

Dubai, United Arab Emirates

Singapore 128461 Singapore

www.Fisher.com

